

EPSILON TIMBER & RECYCLING CRANES

**PALFINGER**

# C70G COMMUNAL

EFFICIENCY FOR  
MUNICIPALITIES.

[PALFINGEREPSILON.COM](http://PALFINGEREPSILON.COM)



# EPSILON C70G COMMUNAL EFFICIENCY FOR MUNICIPALITIES.

INSIDE HOSE ROUTING FOR TOP PROTECTION

LONG OUTREACH AND HIGH CAPACITY

HIGH OPERATING SPEED

SLEWING SYSTEM WITH TWO MOTORS AND SLEWING RING

BEST CONTROLLABILITY WITH RADIO REMOTE CONTROL AND DANFOSS VALVE

OPTIMIZED LOADING HEIGHT IN CLOSE RANGE

## TECHNICAL DETAILS.

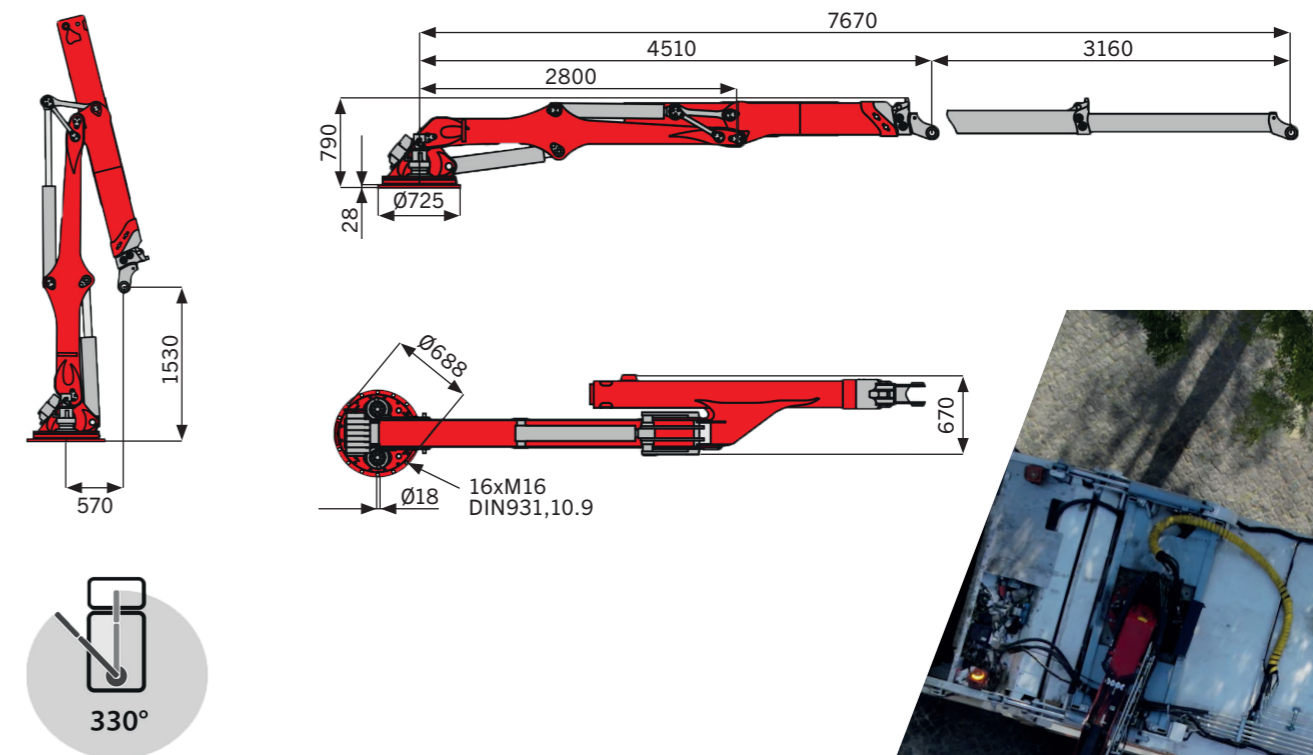

### LIFTING CAPACITY

	3	4	5	6	7	
<b>C70G77</b>	2350	1750	1360	1120	950	[kg]

		<b>C70G77 Communal</b>
Lifting moment net	[kNm]	70
Slewing torque net	[kNm]	17
Slewing angle	[°]	330
Max. outreach	[m]	7,7
Operating pressure	[bar]	240
Recommended pump capacity	1K [l/min]	1 x 100
	1K LS [l/min]	1 x 120
Dead weight without link/rotator	[kg]	1100

Lifted weight, net without accessories; weight of standard crane, incl. oil, spot lights and cylinder protection, without link, rotator, material tolerance +/-5%



# EPSILON TIMBER & RECYCLING CRANES

**PALFINGER**

KP-PR077-M2+EN 06/2023

**EPSILON KRAN GMBH**

Christophorusstraße 30

5061 Elsbethen-Glasenbach | Austria

Tel +43 662 629548-0

epsilon@palfinger.com

**WWW.PALFINGEREPSILON.COM**

KP-PR077 is intended for international use. The availability of some models and the standard and optional equipment may vary from country to country. EPSILON reserves the right to make changes to the design and technical implementation at any time and without prior notice, without undertaking in any way to transfer these to units that have already been sold. Information, descriptions and images correspond to the current status at the time of printing, but can also be changed without prior notice. Illustrations can show certain national versions, special equipment and incomplete standard versions. Dimensions may vary. Load representations are standardized illustrations and do not correspond to the optimal arm position in which the maximum lifting load can be achieved. Subject to technical changes, errors and translation mistakes.

**DEALER:**